

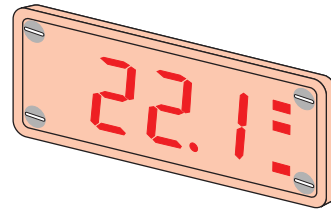

# MultiScan

## Plant Control Model TD-32-MR for Reciprocating Compressor and Standard Condenser or 3C Cooler/Dricon Condenser

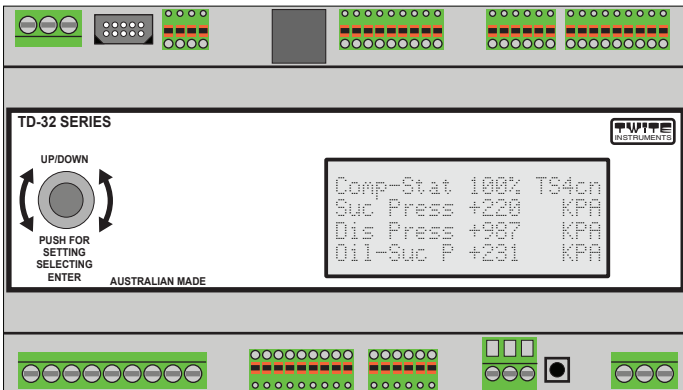

**OPTIONAL LED  
REMOTE PANEL  
DISPLAY**

### FEATURES: -

- Easy menu driven spin control setting.
- 4 x 20 character liquid crystal display.
- Up to 4 Stages Compressor Control.
- Compressor Equalizer Solenoid.
- Compressor Oil Return Solenoid.
- Compressor step and variable control.
- Compressor PID control.
- Compressor Control on Temperature or Pressure.

- Up to 4 Stages Condenser Control.
- Condenser Control on Temperature or Pressure.
- Condenser step and variable control.
- Condenser PID control.
- Condenser Water Dump Control.
- Condenser Celpad Pump Control
- Condenser Wash Control.

- Data logging
- Real time clock
- Rs232 input/output
- Rs485 input/output
- Remote LED panel display of temperature
- Computer SCADA software communication
- Connect to TempScan

### FULL COMPRESSOR CONTROL STEP AND/OR VARIABLE

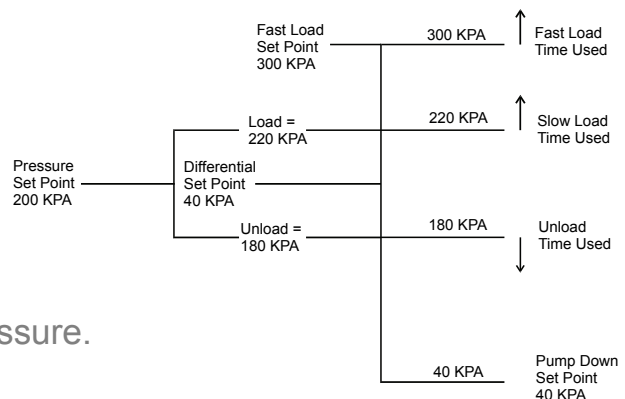

### FULL CONDENSER CONTROL, STEP AND/OR VARIABLE

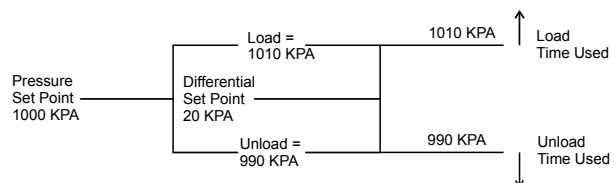

Distributer

**Twite Instruments Pty. Ltd.**  
**18 Flanagan Drive**  
**Tatura Victoria 3616**  
**(03) 5824 1177**  
**0417 50 60 11**  
**www.twite.com.au**